



# **RADIATOR GUARD**

## **Installation Instructions**

**KTM 790/890/890R DUKE**  
**MODEL YEAR 2020+**



Item Number	Title	Quantity
1	Mesh	1
2	Radiator Guard Holder   Top Right   One dot	1
3	Radiator Guard Holder   Top Left   Two dotst	1
4	Radiator Guard Holder   Bottom Left   Three dots	1
5	Radiator Guard Holder   Bottom Right   No dot	1
6	Nut M5   A2   DIN985   ISO10511	4
7	Bolt M5X30   A2   DIN/   ISO7380-1	4
8	Flexible bumper   10x3x7,7 for Fi6	6

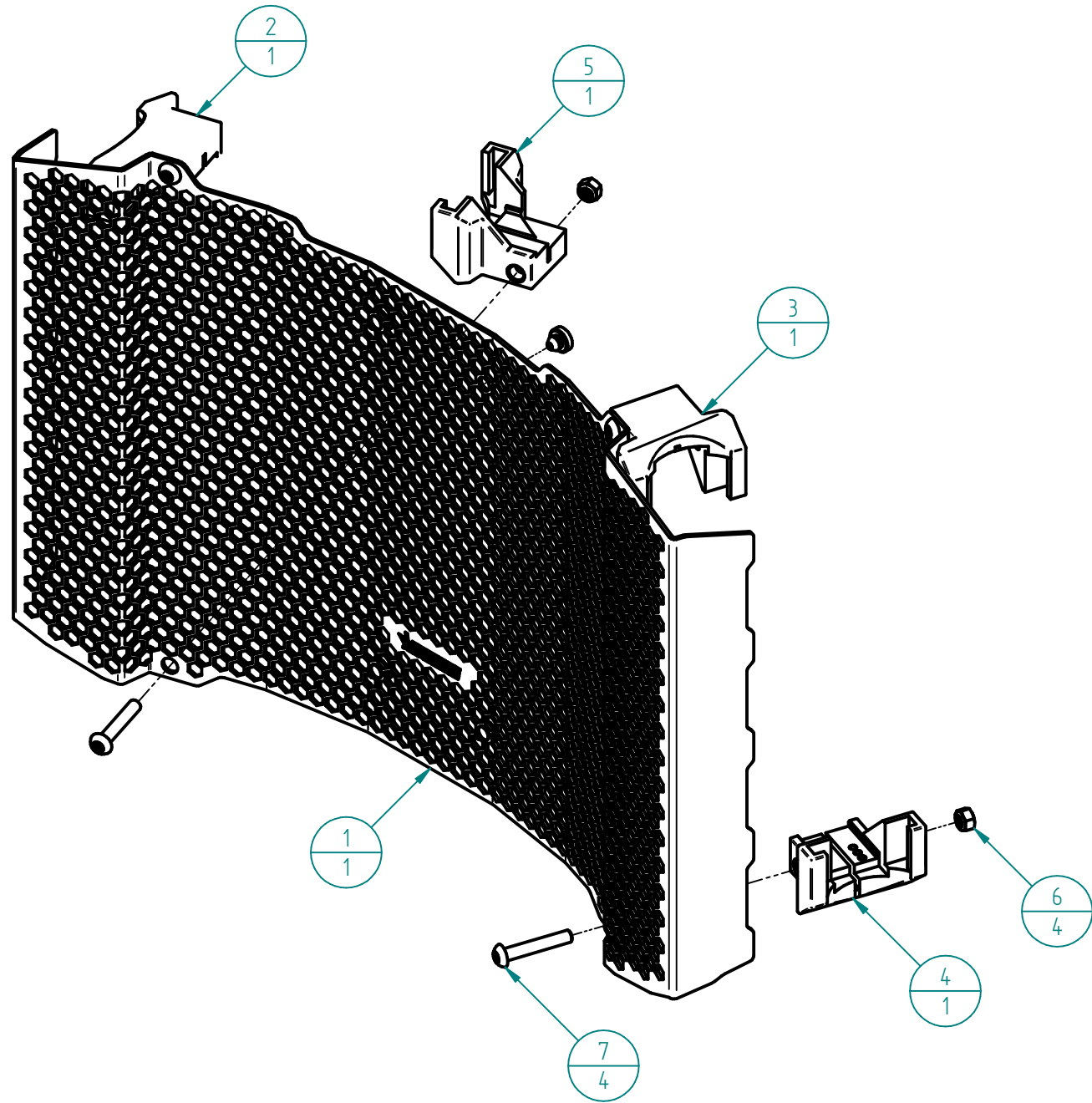

# STEP 1

Check the Radiator Guard holders for the dots as shown in the technical drawing. They should have 1 - 3 dots on each of them (marked with orange dots in the photos).

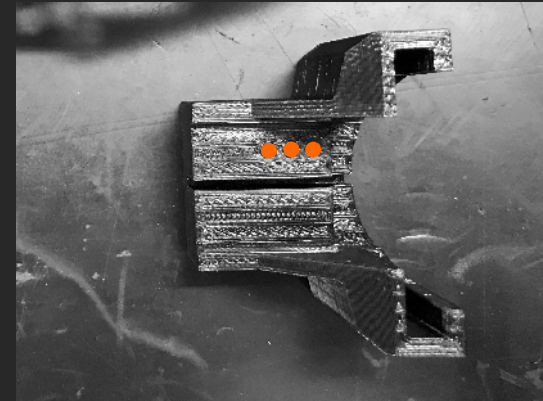
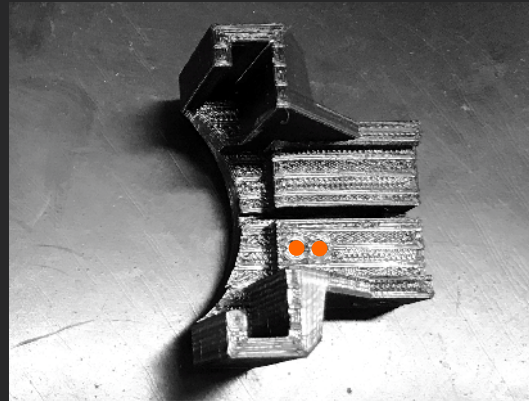
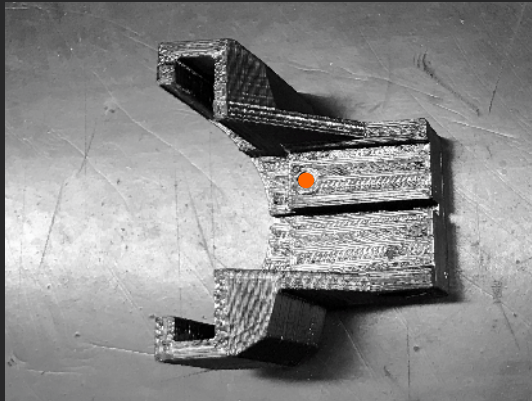

# STEP 1.1

Place the 3 provided elastic bumpers in their designated place. They're easy to find because they're shaped like a Circle instead of the Honeycomb.

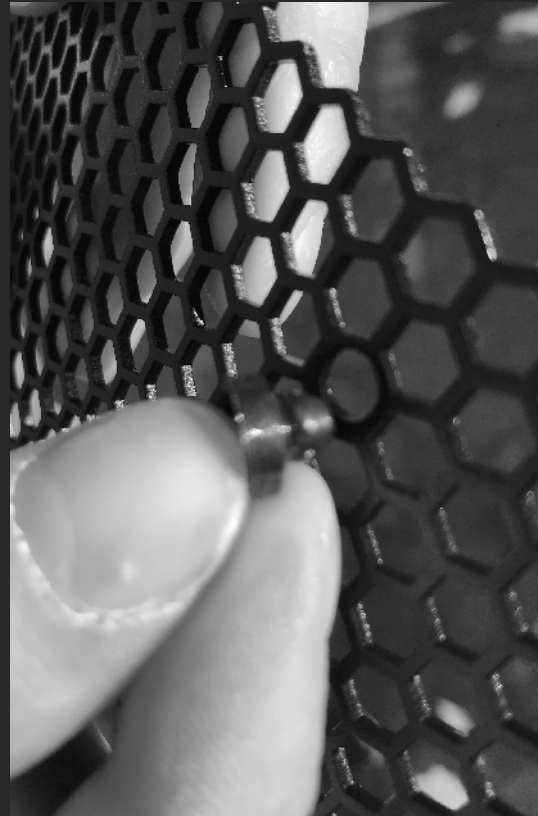
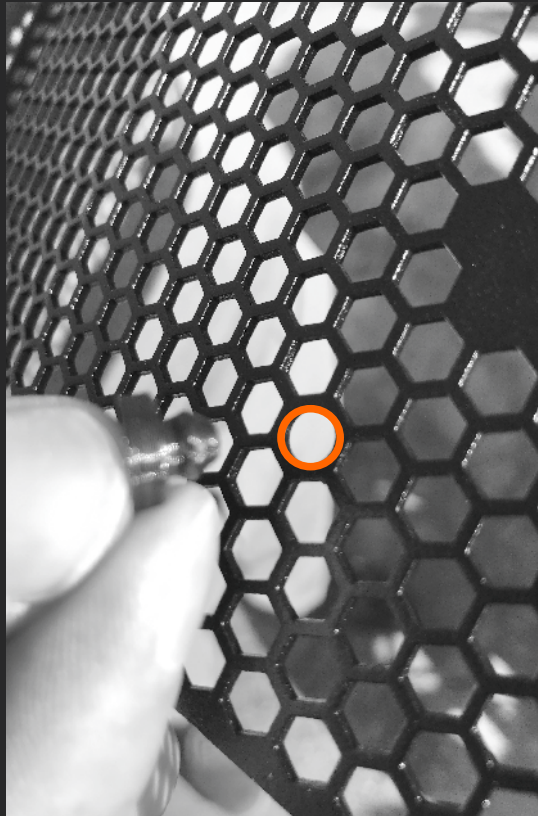



# STEP 2

Take the 4 nuts & place them each in their designated place as shown in photo. Make sure they're facing the right way!

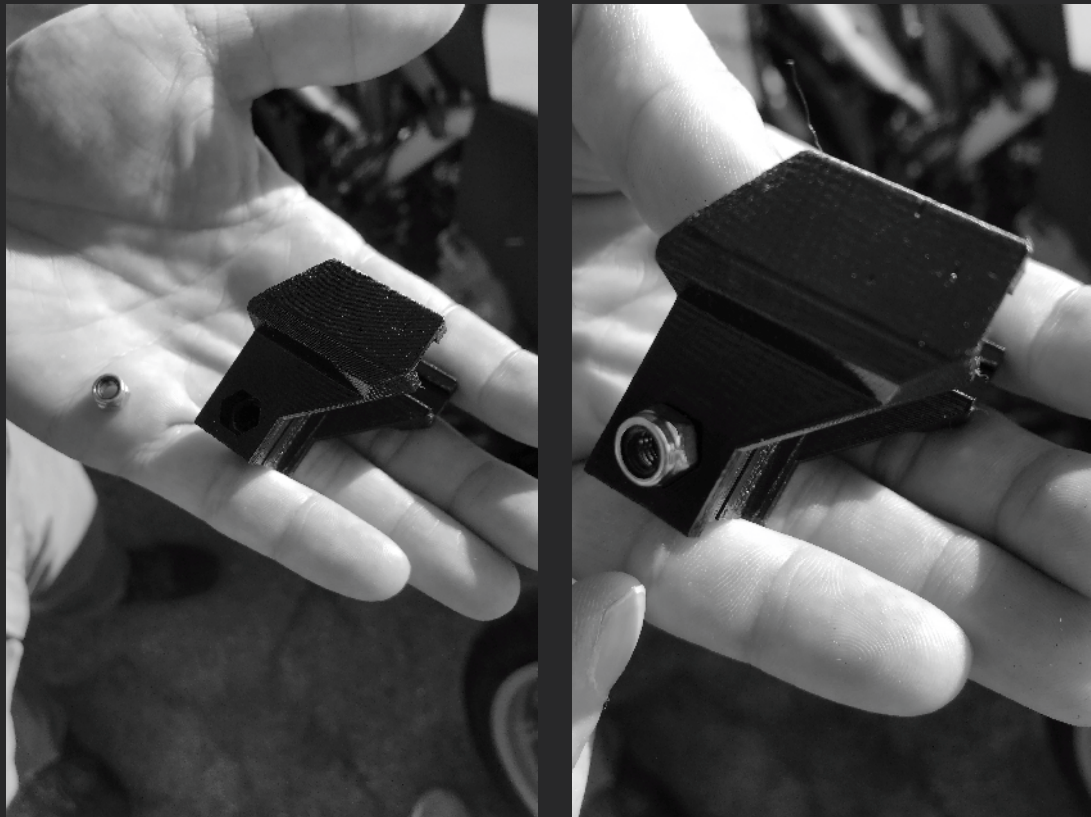

# **STEP 3**

Place the Radiator guard holders in each corner of the Radiator guard. (Looking from the driving position) The top right should have 1 DOT, the top left should have 2 DOTS, the bottom left 3 DOTS & the bottom right is with NO DOTS (it has a slice & is different from others).

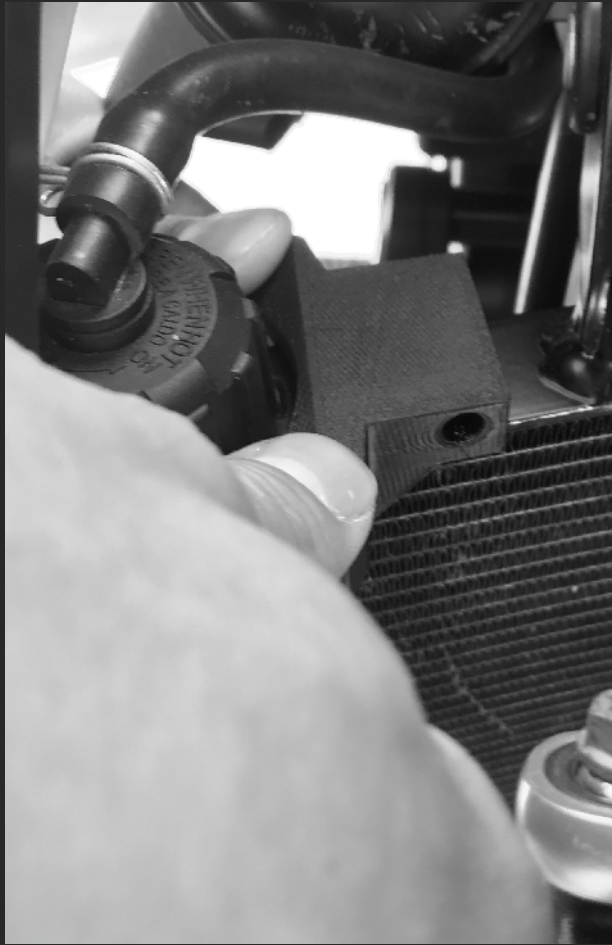



# STEP 4

Place the Radiator Guard in it's place & line it up with the holder holes.

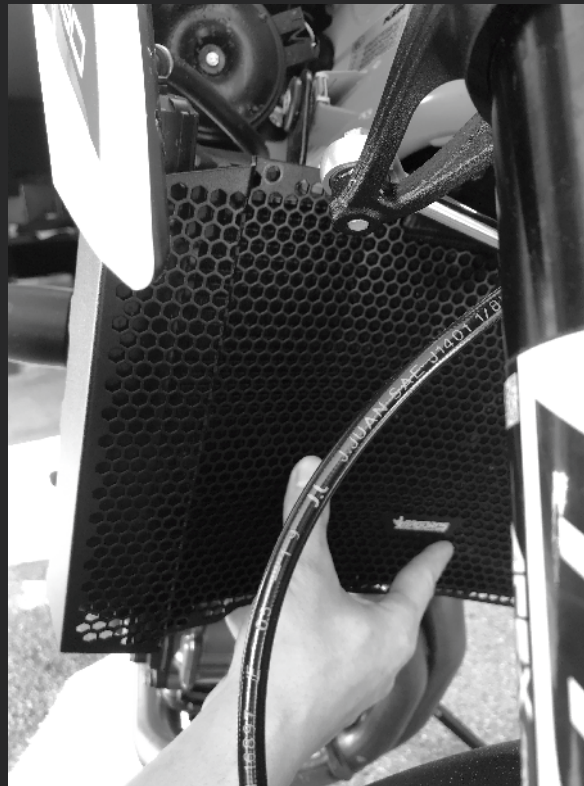

# STEP 5

Place the 4 provided bolts in each hole & tighten them in a criss-cross pattern.

Good Job! You're done & can now safely drive on the streets with your Radiator protected.





## **IMPORTANT**

**It is recommended that periodic inspections are made to ensure that all bolts are tightened to the specified torque settings. Should the bike be involved in an accident a thorough inspection should be made and any components that have taken an impact, no matter how small, be replaced.**

**The manufacturer or supplier cannot be held responsible for products that are incorrectly mounted or inappropriately used.**

**It is recommended to check all connections regularly for tightness of fit.**



<https://bagorosperformance.com/product/radiator-guard-for-ktm-890-890rduke/>